

---

# STEERING SYSTEM

## PRECAUTION

1. **HANDLING PRECAUTIONS ON STEERING SYSTEM**
  - (a) Care must be taken when replacing parts. Incorrect replacement may affect the performance of the steering system and result in driving hazards.
2. **HANDLING PRECAUTIONS ON SRS AIRBAG SYSTEM**
  - (a) The vehicle is equipped with SRS (Supplemental Restraint System) such as the driver airbag and front passenger airbag. Failure to carry out service operations in the correct sequence could cause the SRS to unexpectedly deploy during servicing. This may cause a serious accident. Before servicing (including inspection, replacement, removal and installation of parts), be sure to read the precautionary notices for the supplemental restraint system (see page [RS-1](#)).

**SR**

## PROBLEM SYMPTOMS TABLE

### STEERING SYSTEM

Symptom	Suspected area	See page
Hard steering	1. Tires (Improperly inflated)	TW-1
	2. Power steering fluid level (Low)	PS-2
	3. Drive belt (Loose)	PS-2
	4. Front wheel alignment (Incorrect) (2WD)	SP-2
	5. Front wheel alignment (Incorrect) (4WD)	SP-2
	6. Steering system joints (Worn)	-
	7. Suspension arm ball joints (2WD) (Worn)	SP-22
	8. Suspension arm ball joints (4WD) (Worn)	SP-22
	9. Steering column (Binding)	-
	11. Power steering vane pump	PS-8
	12. Power steering gear (2WD)	PS-18
	13. Power steering gear (4WD)	PS-37
	Poor return	1. Tires (Improperly inflated)
2. Front wheel alignment (Incorrect) (2WD)		TW-1
3. Front wheel alignment (Incorrect) (4WD)		TW-1
4. Steering column (Binding)		-
5. Power steering gear (2WD)		PS-18
6. Power steering gear (4WD)		PS-37
Excessive free play	1. Steering system joints (Worn)	-
	2. Suspension arm ball joints (Worn) (2WD)	SP-22
	3. Suspension arm ball joints (Worn) (4WD)	SP-22
	4. Intermediate shaft, Sliding yoke (Worn)	-
	5. Front wheel bearing (Worn) (2WD)	SP-22
	6. Front wheel bearing (Worn) (4WD)	SP-22
	7. Power steering gear (2WD)	PS-18
	8. Power steering gear (4WD)	SP-20
Abnormal noise	1. Power steering fluid level (Low)	PS-2
	2. Steering system joints (Worn)	-
	4. Power steering vane pump	PS-8
	5. Power steering gear (2WD)	PS-18
	6. Power steering gear (4WD)	PS-37

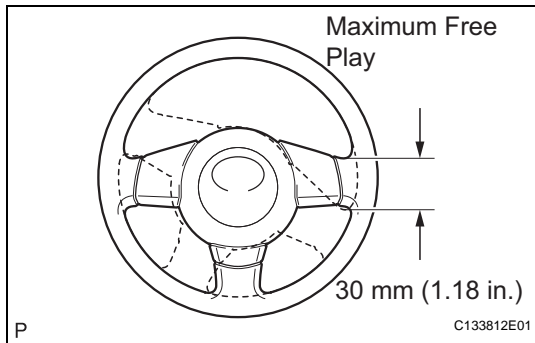

## ON-VEHICLE INSPECTION

### 1. CHECK STEERING WHEEL FREE PLAY

- Stop the vehicle and align the tires facing straight ahead.
- Gently turn the steering wheel right and left by hand, and check the steering wheel free play.

#### Maximum free play:

**30 mm (1.18 in.)**

If the free play exceeds the maximum, replace the steering intermediate shaft or steering gear.